



JOTUN

Jota Armour

Working Manual

Jota Armour

Packaging

Jota Armour is despatched as a kit.

The kit consists of three components:

- Component A = 4.13 litres of epoxy
- Component B = 0.70 litres of epoxy hardener
- Component C = 14 kg of blended aggregate

All three components are packaged within a 20 litre drum.

When mixed there is a total of 9 litres.

This drum is referred to as the mixing drum.

How to mix

1. Remove all components from the mixing drum.
2. Mix components A & B together using a mechanical mixer.
3. Pour the mixed A & B liquid into the 20 litre mixing drum.
4. Whilst mechanically mixing the liquid add all the component C aggregate. Ensure that all the aggregate has been mixed into the epoxy. The resultant mix will be quite stiff and have a similar consistency to wet concrete. At high temperatures No.17 thinner may need to be added.
5. The mixed Jota Armour is now ready to be applied.

Application using a gravity feed hopper gun

Equipment required:

- Gravity feed hopper gun fitted with a 4–8 mm tip
- ¼ inch airline
- Air compressor (3.5–4 bar / 200 litres per min)
- Goggles
- Face mask
- Thinner No. 17

1. Connect the airline to the hopper gun air intake point as marked on the diagram below.

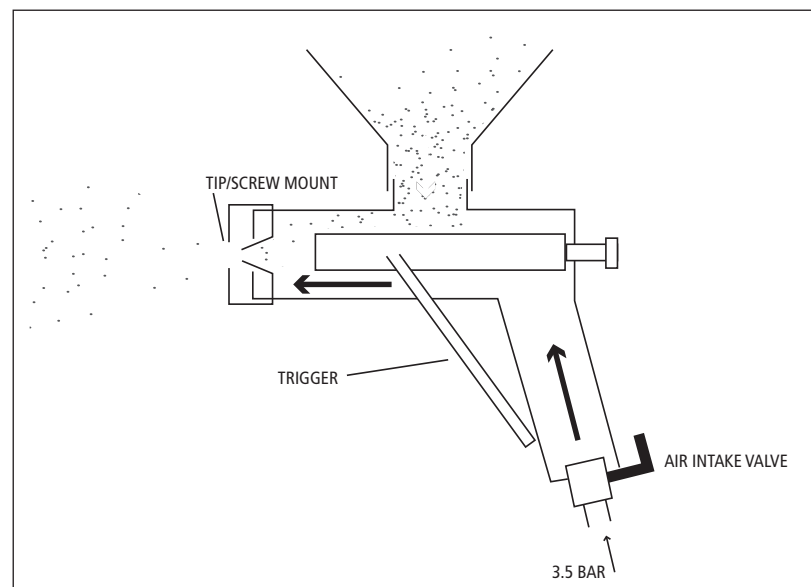

2. Set air compressor at the required pressure.
3. Ensure that the hopper gun valve at the base of the air intake point is closed.

Application using a gravity feed hopper gun (continued)

4. Add the Jota Armour mixture into the hopper.
5. Fully compress the trigger on the hopper gun.
6. Point the gun away from the area to be coated. Slowly open the hopper gun air intake valve. At first insufficient air will pass through the gun and the Jota Armour will 'drip' from the tip – i.e no spray will be formed.

As the valve is opened further a splatter spray will form. It is possible that if the pressure from the compressor is too high the spray formed will be too violent which can cause the aggregate to come out of suspension.

It is therefore important to ensure that the valve is set just over the point at which sufficient airflow produces a spray.

7. You are now ready to spray Jota Armour.
8. The gun should be directed at the substrate to be coated at an angle of approximately 45 degrees to the horizontal and a distance of about 50 cm from the substrate.
9. Compress the trigger and move the gun in a slow circular motion to ensure even distribution.

Ensure that you do not over apply the product.

Signs of over application are:

- Pools of wet epoxy forming on the surface. This is because at very high WFT the aggregate will come out of solution.
- Globules of product forming on the substrate. This may also be caused by insufficient pressure at the gun or a blockage in the gun.

10. We recommend using a base primer of a contrasting colour beneath the Jota Armour. This will assist in identifying holidays.

Ensure that these are recoated.

11. After approximately 5 drums of product have been applied it is advisable to wash through the gun with No.17 thinner to prevent build up of product within the system.

Occasionally, a small piece of wire may be needed to clear the tip.

DO NOT REMOVE the screw-mounted tip during spray as aggregate will enter the threads and reassembly will cause damage.

How to coat deck edges

It is not advisable to apply Jota Armour right to the deck edge or the edge of a bulkhead or upstand as build up of product will be formed at this point.

We recommend that edges of decks be masked to a perimeter of approximately 10 cm.

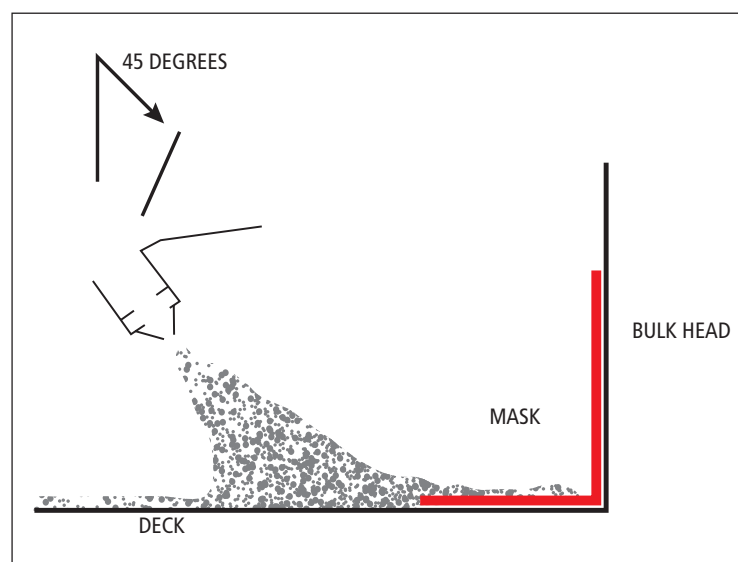

Jota Armour

Application



1. Standard hopper gun

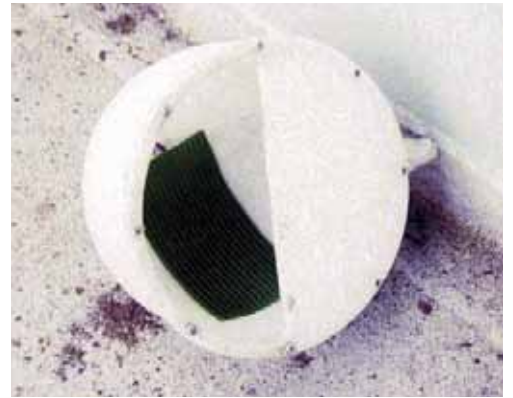

2. Hopper gun bucket



3. Required mixing equipment

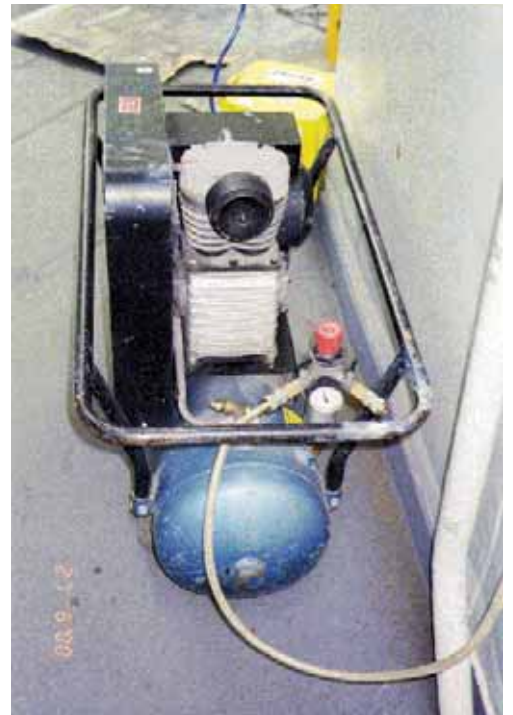

Compressor – 3HP



5. Pre-primed deck with Jotamastic masked off because of overspray

Application
(continued)



6. Application – circular motion should be used



7. Application – circular motion should be used



8. Application – circular motion should be used

www.jotun.com



HEAD OFFICE

Jotun A/S
P.O.Box 2021, 3248 Sandefjord, Norway
Tel: +47 33 45 70 00 Fax: +47 33 45 79 00